

Surge Arresters

**UltraSIL™ Polymer-Housed VariSTAR™ Type U4
Surge Arrester for Systems through 275 kV IEC
20-kA; Line Discharge Class 4**

Electrical Apparatus
1235-99

GENERAL

Cooper Power Systems has set a new standard of excellence for polymer-housed station-class surge arresters. Enhancements in arrester design allow Cooper Power Systems to offer increased cantilever strength and improved energy handling capability. The UltraSIL™ Polymer-Housed VariSTAR™ Type U4 Station-Class Arresters incorporate the industry recognized superior silicone rubber housing with a unique high creep alternating shed profile designed to withstand the most extreme environments. The "standard" silicone rubber housing is designed with a minimum specific creepage distance of 31 mm/kV L-L, which meets category IV (Very Heavy) pollution level according to the IEC standard. This housing is applied over a gapless MOV internal design.

Cooper Power Systems Type U4 arresters meet or exceed the requirements of IEC 60099-4 Rev 2009.

TABLE 1
UltraSIL Housed Type U4 Class 4
Ratings and Characteristics

Arrester Characteristic	Rating		
Arrester Voltage Ratings, U_r	3-240 kV		
Rated Discharge Energy	Single Impulse	Double Impulse*	
	kJ/kV of U_c	10	12
	kJ/kV of U_r	8.3	10
System Frequency (Hz)	50/60		
Nominal Discharge Current (kA)	20		
High Current Withstand, Short Duration Withstand 4/10 μ s (kA)	100		
Short-Circuit/Pressure Relief Rating (kA rms sym.)	65		
Cantilever Strength (Nm)	Ultimate	SLL**	SSL***
	4000	1600	2000
Ambient Temperature (°C)	-40 to +40		
Standard Pollution Level (Creep)	Very Heavy (31 mm/kV)		

* Double impulse rating assumes a two shot energy discharge within one minute.

** Specified Long Term Load

*** Specified Short Term Load



Figure 1.
UltraSIL Polymer-Housed VariSTAR Class 4 Surge Arrester family.

CONSTRUCTION

The unique construction of UltraSIL Polymer-Housed Class 4 Arresters begins with world class Metal Oxide Varistor (MOV) disks produced at our manufacturing facility in Olean, NY. By manufacturing our own disks we maintain a strict quality control over the entire production process, from initial raw material inspection to final physical and electrical testing of each disk. In addition, by controlling the manufacturing process of both disks and arresters, we achieve the optimal combination. Cooper Power Systems produces MOV disks of unsurpassed quality through continuous

improvements in disk formulation and manufacturing technology. The end result is a long history of in-service use with outstanding durability and protective capability.

Arrester production begins by stacking glass-collared MOV disks in series with aluminum end electrodes. Our proprietary process wraps the assembly with a high-strength woven fiberglass-reinforced epoxy composite. When cured, the arrester module is capable of withstanding high electrical and cantilever load conditions.

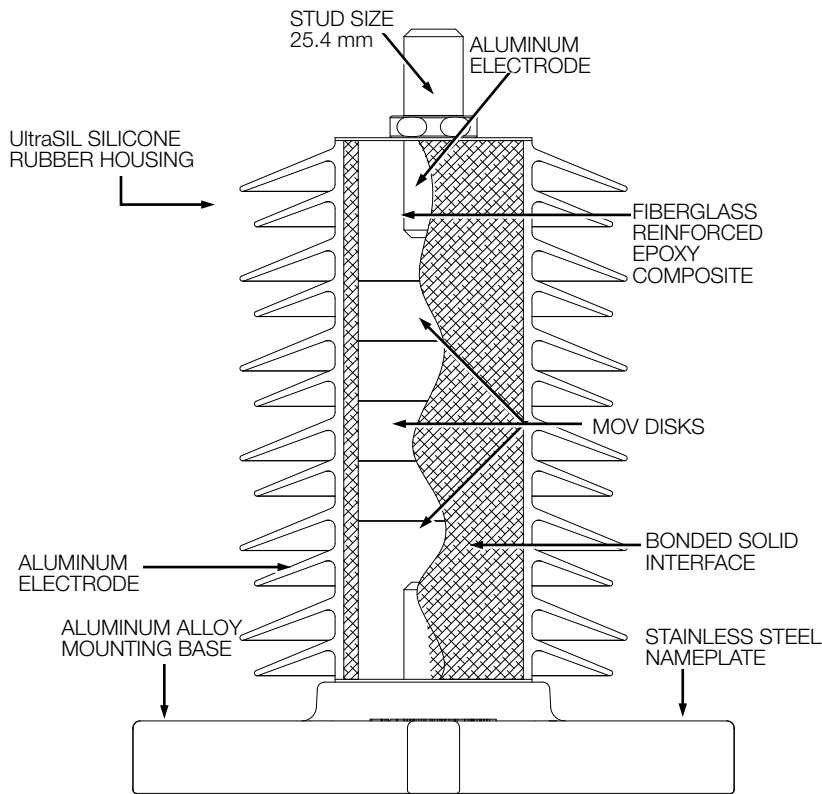

Figure 2.
Cutaway illustration of a 10 kV UltraSIL Polymer-Housed VariSTAR Class 4 Arrester.

The UltraSIL silicone rubber housing utilizes an interference fit and is bonded onto the internal module to form a solid, void-free, high-dielectric strength insulation system. Once the housing is in place, each arrester must pass a strict series of electrical tests to insure the highest level of in-service performance.

The silicone rubber housing results in lighter weight than similarly rated porcelain housed arresters. The silicone rubber housing is also less sensitive to physical damage than porcelain. Also, when compared to other polymeric housing materials, silicone rubber generates significantly lower external power losses under contaminated conditions.

FEATURES

The UltraSIL silicone rubber housing was chosen for its superior insulation performance when compared to other polymeric housing materials. Long term environmental testing has verified the superiority of UltraSIL silicone rubber when compared to other polymeric insulating materials.

Independent laboratory tests have verified the superior water repellent behavior of silicone rubber, which is responsible for the lower external

power losses, higher resistance to UV degradation and surface tracking, superior performance in contaminated environments, and other important insulating properties. Also, UltraSIL silicone rubber has been proven not to support biological growth and is non-flammable.

The basic silicone rubber housed arrester can be customized with a variety of terminal and mounting options which allow users to select the features that meet their application needs. The "standard" silicone rubber housing is designed with a minimum specific creepage distance of 31 mm/kV L-L, but if additional creepage is required, please contact your Cooper Power Systems representative for customized options.

OPERATION

The operation of the VariSTAR arrester is typical of gapless metal oxide arresters. During steady state conditions, line-to-earth voltage is continuously across the arrester terminals. When overvoltages occur, the VariSTAR arrester immediately limits the overvoltage to the required protective level by conducting only the necessary level of surge current to earth. Upon passage of the overvoltage condition, the arrester

returns to its initial condition, once again conducting only minimal leakage current.

UltraSIL Polymer-Housed VariSTAR Class 4 Arresters are ideal for the protection of critical substation apparatus in areas of moderate lightning incidence and for protection against switching surges generated on transmission systems.

Pressure relief tests have been conducted in accordance with IEC 60099-4 to demonstrate the UltraSIL Polymer-Housed VariSTAR Class 4 Arrester's ability to withstand fault currents for specific durations.

DESIGN TESTING

The housing material, internal components and hardware work as a system to withstand years of exposure to environmental extremes. To assure a superior level of performance, the components and the assembled arrester unit have been subjected to a testing program that accurately simulates years of exposure to field conditions. Tests include:

IEC 60099-4 Testing - Full Certification to performance requirements by an independent laboratory has been completed. A certified test report is available upon request.

Additional design verification of the UltraSIL Housed VariSTAR Class 4 Arrester includes testing for:

- Ultraviolet Withstand
- High Voltage Dielectric Integrity
- Wet Arc Tracking Resistance
- Thermal Shock
- Coefficients of Expansion and Materials Compatibility
- Cantilever Strength
- Terminal Torque

For detailed reports please contact your Cooper Power Systems sales representative.

ROUTINE TESTS

A complete automated production test program ensures a quality product. Each metal oxide varistor receives a series of electrical tests. Quality is further demonstrated by tests performed to destruction on samples from every batch of varistors.

Routine tests on the varistor disks performed in accordance with IEC 60099-4:

- 100% Physical Inspection
- 100% Discharge Voltage Test
- 100% V_{ref} at 17 mA
- 100% Watts Loss Measured at $1.05 \times MCOV$
- 100% Transmission Line Discharge Energy Test
- Batch High-Current, Short-Duration Test
- Batch Thermal Stability Test
- Batch Aging Test

Routine tests on each fully assembled UltraSIL Polymer-Housed VariSTAR Class 4 Arrester, per IEC 60099-4.

- 100% Physical Inspection
- 100% V_{ref} Test
- 100% Watts Loss Test
- 100% Partial Discharge Inception Voltage Test

GENERAL APPLICATION RECOMMENDATIONS

The rating of an arrester is the maximum power-frequency line-to-earth voltage at which the arrester is designed to pass the IEC operating duty test. Table 2 provides a general guide for the selection of the proper arrester for a given system voltage. Cooper Power Systems application engineers are available to make specific system application recommendations.

SELECTION OF ARRESTER RATING

In arrester rating selection it is preferable to determine the lowest arrester rating that will ensure satisfactory operation. This is the optimum solution because the arrester selected will not only provide the greatest margin of insulation protection but also be the most economical choice.

Increasing arrester ratings above the minimum increases the likelihood of the arrester surviving varying system conditions but compromises the protection of equipment insulation. Table 2 lists VariSTAR U4 arrester ratings commonly used on various three-phase systems.

TABLE 2
Arrester Ratings Commonly Used on Three-Phase Systems

System Voltages L-L (kV)		Arrester Ratings (kV)	
Nominal	Maximum	Grounded Circuits	High-Impedance/ Ungrounded Circuits
3.3	3.7	3	6
6.6	7.3	6	9
10.0	11.5	9	12-15
11.0	12.0	9-10	
16.4	18.0	15.0	18-21
22.0	24.0	18-21	24-27
33.0	36.3	27-30	36-39
47.0	52.0	39-48	54-60
66.0	72.0	54-60	66-84
91.0	100	78-84	90-96
110	123	96-108	120-135
132	145	108-120	132-144
155	170	132-144	162-172
220	245	180-198	204-240
275	300	216-240	-

Rating selection should begin with consideration of the maximum system operating voltage. The maximum power frequency voltage expected under normal system conditions (expressed line-to-earth) should not exceed the selected arrester's continuous operating voltage (U_c).

The temporary overvoltage (TOV) capability of the VariSTAR U4 arrester is shown in Figure 3. The curves indicate the arrester's ability to withstand abnormal system power frequency (sinusoidal) overvoltages for various durations. The values shown assume that the arrester has been energized at COV (U_c) prior to an overvoltage event, that the arrester is in an ambient temperature of 60°C , and that after the overvoltage durations shown, demonstrate that the arrester will thermally recover when once again energized at COV (U_c).

The voltage withstand capability for application on ungrounded systems after IEC high current duty is 1.076 per unit of COV (U_c) for 24 hours. For ungrounded systems utilizing high impedance or resonant grounding and other systems where the line-to-earth voltages exceed this stated TOV capability, arresters having a COV (U_c) equal to line-to line voltage may be required.

For non-sinusoidal transient voltages caused by system switching

operations a transient network analyzer (TNA) study is recommended; Cooper Power Systems engineers are available to make these studies.

Figure 3 also illustrates the arrester's TOV capabilities with and without prior switching surge duties of up to a maximum capability of 10 kJ/ kV of COV (U_c)-single impulse and 12 kJ/ kV of COV (U_c)-double impulse.

To assure proper application the following information is normally required:

1. Maximum system operating voltage.
2. System grounding conditions.
 - A. For four-wire circuits, grounding conditions depend upon whether the system is multi-grounded, whether it has neutral impedance, and whether common primary and secondary neutrals are used.
 - B. For three-wire circuits, grounding conditions depend upon whether the system is solidly grounded at the source, grounded through the neutral impedance at the source grounded through transformers, or ungrounded.

Where unusual conditions exist (high ground resistance, high capacitive load, unusual switching surge duty, etc.), the following supplementary

information is required:

- Type of unusual condition
- BIL of equipment and separation distance to protected equipment
- Type of construction (phase spacing, length of line, conductor size, etc.)
- Grounding and phase-sequence components of source impedances
- Phase-sequence components of load impedances
- Available fault current
- Potential for loss of neutral earthing during system events

PERFORMANCE AND PROTECTIVE CHARACTERISTICS

Table 4, "Protective Characteristics of the UltraSIL Polymer-Housed VariSTAR U4 Surge Arrester" displays the Arrester Rating (U_r), Continuous Operating Voltage (U_c) and the guaranteed protective characteristics.

The Steep Current Impulse protective level is the maximum residual voltage for a 10 kA impulse current that crests in one microsecond. Lightning Impulse Residual Voltages represent the maximum protective levels exhibited by the arrester when discharging lightning currents of the standard 8/20 microsecond waveshape. The maximum Switching Impulse Residual Voltages are based on a switching surge current having a time to crest of 30 microseconds. For all ratings the switching surge energy absorption capability is 10 kJ/kV of U_c -single impulse and 12 kJ/kV of U_c -double impulse.

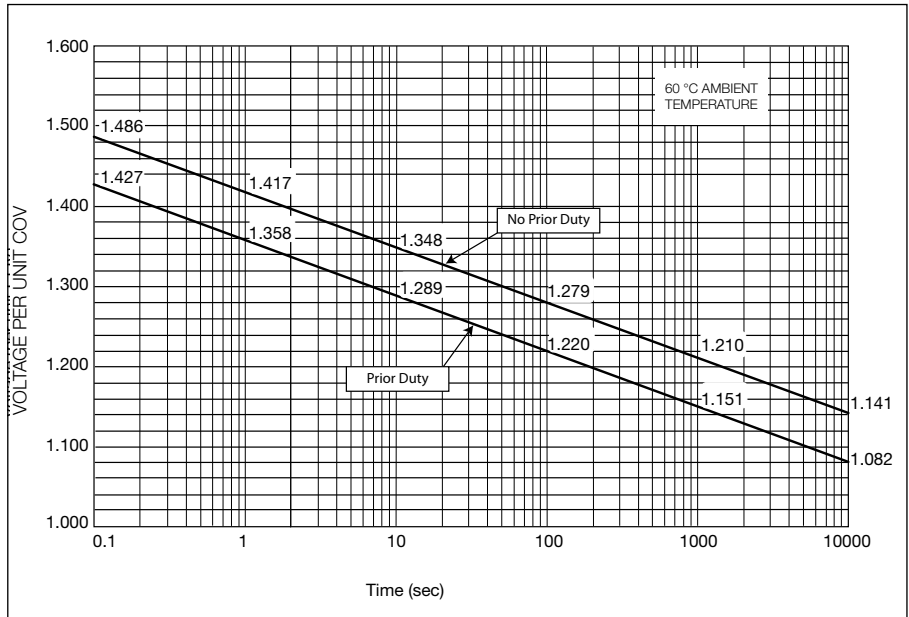

Figure 3. Temporary Overvoltage Capability of VariSTAR U4 Surge Arresters.

Note: The 24-Hour TOV with prior duty is 1.076 per unit of U_c . The TOV curve in Figure 3 applies to standard electrical build arresters. Consult manufacturer for further information regarding alternate electrical builds. See Table 4 for Temporary Over Voltage w/Prior Duty (kV) for 1 and 10 second values.

TABLE 3 Insulation Withstand Voltages

Housing Designation	Housing Leakage Distance -Creep (mm)	Strike (mm)	Insulation Withstand Voltages			
			BIL 1.2/50µs dry Impulse (kV, Pk)	Switching Surge Impulse, 250/2500 µs (kV, crest)	WET 50/60 Hz 60 Sec (kV, rms)	DRY 50/60 Hz 60 Sec (kV, rms)
08	780	201	126	N/A	58	82
10	975	240	138		70	90
12	1170	280	159		83	104
14	1365	319	179		96	117
16	1560	359	206		116	135
18	1755	398	220		121	144
22	2145	477	262		151	168
24	2340	515	281		159	184
26	2535	554	300		174	202
28	2730	594	321		184	211
30	2925	634	342		197	224
32	3120	673	364		205	237
40	3900	875	482		272	312
44	4290	954	524		302	336
46	4485	992	543		310	352
48	4680	1030	562		318	368
50	4875	1069	581		333	386
52	5070	1108	600		348	404
54	5265	1148	621		358	413
56	5460	1188	642		368	422
60	5850	1268	684		394	448
64	6240	1346	728		410	474
78	7605	1662	900		522	606
80	7800	1702	921		532	615
82	7995	1742	942		542	624
84	8190	1782	963		555	637
86	8385	1821	985	1029	563	650
88	8580	1861	1006	1052	576	663
92	8970	1940	1049	1083	594	685
94	9165	1980	1070	1106	607	698
A6	10335	2256	1221	1296	706	817
B0	10725	2336	1263	1320	726	835
B2	10920	2376	1284	1332	736	844

TABLE 4
Protective Characteristics of the UltraSIL Polymer-Housed VariSTAR U4 Surge Arrester

Arrester Rating U_r (kV, rms)	Arrester COV U_c (kV, rms)	Steep Current Residual Voltage (kV Crest)	Lightning Impulse Residual Voltage (kV Crest) 8/20 μ s Current Wave						"Switching Impulse Residual Voltage (kV Crest) 30/60 Current Wave"				Temporary Over Voltage w/Prior Duty (kV)	
			1.5 kA	3 kA	5 kA	10 kA	20 kA	40 kA	125 A	250 A	500 A	1000 A	1 Second	10 Seconds
3	2.55	7.8	6.3	6.6	6.9	7.4	7.9	8.7	5.6	5.7	5.9	6.1	3.5	3.3
6	5.1	15.5	12.6	13.2	13.7	14.8	15.8	17.4	11.2	11.4	11.8	12.2	6.9	6.6
9	7.65	23.2	18.9	19.8	20.6	22.2	23.7	26.1	16.7	17.1	17.6	18.3	10.4	9.9
10	8.4	25.5	20.8	21.7	22.6	24.3	26	28.6	18.4	18.8	19.4	20.1	11.4	10.8
12	10.2	30.9	25.2	26.4	27.4	29.5	31.6	34.8	22.3	22.8	23.5	24.3	13.9	13.1
15	12.7	38.5	31.4	32.8	34.1	36.8	39.3	43.3	27.8	28.4	29.3	30.3	17.2	16.4
18	15.3	46.3	37.8	39.5	41.1	44.3	47.3	52.1	33.4	34.2	35.2	36.5	20.8	19.7
21	17	51.5	42	43.9	45.6	49.2	52.6	57.9	37.1	38	39.2	40.5	23.1	21.9
24	19.5	59.1	48.1	50.4	52.3	56.4	60.3	66.4	42.6	43.6	44.9	46.5	26.5	25.1
27	22	66.6	54.3	56.8	59.1	63.6	68	74.9	48.1	49.2	50.7	52.4	29.9	28.4
30	24.4	73.9	60.2	63	65.5	70.6	75.4	83.1	53.3	54.6	56.2	58.2	33.1	31.5
33	27.5	83.3	67.8	71	73.8	79.5	85	93.7	60.1	61.5	63.3	65.5	37.3	35.4
36	29	87.8	71.5	74.9	77.8	83.9	89.6	98.8	63.3	64.8	66.8	69.1	39.4	37.4
39	31.5	95.4	77.7	81.3	84.5	91.1	97.4	108	68.8	70.4	72.5	75.1	42.8	40.6
42	34	103	83.9	87.8	91.2	98.3	106	116	74.2	76	78.3	81	46.2	43.8
45	36.5	111	90	94.2	97.9	106	113	125	79.7	81.6	84	87	49.6	47
48	39	119	96.2	101	105	113	121	133	85.1	87.2	89.8	92.9	53	50.3
54	42	128	104	109	113	122	130	143	91.7	93.9	96.7	101	57	54.1
60	48	146	119	124	129	139	149	164	105	108	111	115	65.2	61.9
66	53	161	131	137	143	154	164	181	116	119	122	127	72	68.3
72	57	173	141	148	153	165	177	195	125	128	132	136	77.4	73.5
78	62	188	153	161	167	180	192	212	136	139	143	148	84.2	79.9
84	68	206	168	176	183	197	211	232	149	152	157	162	92.3	87.7
90	72	218	178	186	194	209	223	246	158	161	166	172	97.8	92.8
96	76	230	188	197	204	220	235	259	166	170	175	181	103.2	98
	77	233	190	199	207	223	238	263	169	173	178	184	104.6	99.3
108	84	255	208	217	226	243	260	286	184	188	194	201	114.1	108.3
120	98	297	242	253	263	284	303	334	214	219	226	234	133.1	126.3
132	106	321	262	274	285	307	328	361	232	237	244	253	143.9	136.6
138	111	336	274	287	298	321	343	378	243	248	256	265	150.7	143.1
144	115	348	284	297	309	333	356	392	251	257	265	274	156.2	148.2
150	120	364	296	310	322	347	371	409	262	269	277	286	163	154.7
162	130	394	321	336	349	376	402	443	284	291	300	310	176.5	167.6
168	131	397	323	339	352	379	405	446	286	293	302	312	177.9	168.9
172	140	424	346	362	376	405	433	477	306	313	323	334	190.1	180.5
180	144	436	355	372	387	417	445	491	315	322	332	343	195.6	185.6
192	152	460	375	393	408	440	470	518	332	340	350	362	206.4	195.9
198	160	485	395	413	430	463	495	545	350	358	369	382	217.3	206.2
204	165	500	407	426	443	477	510	562	361	369	380	393	224.1	212.7
216	174	527	429	450	467	503	538	593	380	389	401	415	236.3	224.3
228	180	545	444	465	483	521	557	613	393	403	415	429	244.4	232
240	190	575	469	491	510	550	587	647	415	425	438	453	258	244.9

Dimensions and Mounting

Figure 4 illustrates an in-line mounting arrangement; the applicable values of "B" and "C" may be found in Table 5. Line and Earth terminal details are shown on pages 10-11, options 14 and 15. Figure 5 shows an outline drawing of the standard U4 UltraSIL Polymer-Housed VariSTAR Class 4 Arrester. The values for dimensions "A" and "D" for all ratings are listed in Table 5.

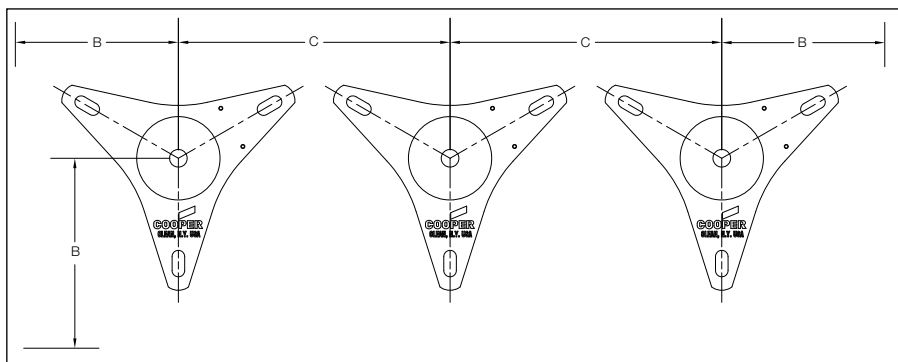

Figure 4.
Three-phase in-line mounting.

Note: Refer to Table 5 for Dimensions B and C.

TABLE 5
Catalog Numbers and Dimensional Information and Weights for VariSTAR U4 Surge Arresters¹

Arrester Rating U_r (kV, rms)	Arrester COV U_c (kV, rms)	Standard Arrester Catalog Number	Dim. A (mm)	Dim. D (mm)	Dimension B Minimum Phase-to-Earth Clearance* (mm)	Dimension C Minimum Phase-to-Phase Clearance* (mm)	Housing Leakage Distance** (mm)	Arrester Mass (kg)	Grading Ring Diameter (mm)	Number of Sections
3	2.55	U4AA003002A0845AAA	208	151	140	254	780	7	—	1
6	5.1	U4AA006005A1045AAA	247		141	255	975	8		
9	7.65	U4AA009007A1045AAA			144	258				
10	8.4	U4AA010008A1045AAA	287		153	267	1170	9		
12	10.2	U4AA012010A1245AAA			168	283				
15	12.7	U4AA015012A1245AAA	326		188	302	1365	10		
18	15.3	U4AA018015A1445AAA			218	332				
21	17	U4AA021017A1445AAA	366		204	319	1560	12		
24	19.5	U4AA024019A1645AAA			225	339				
27	22	U4AA027022A1645AAA	405		244	358	1755	15		
30	24.4	U4AA030024A1845AAA			269	384				
33	27.5	U4AA033027A1845AAA	484		282	396	2145	16		
36	29	U4AA036029A1845AAA			302	416				
39	31.5	U4AA039031A2245AAA	523		322	436	2340	17		
42	34	U4AA042034A2245AAA			342	457				
45	36.5	U4AA045036A2445AAA	563		363	477	2535	20		
48	39	U4AA048039A2645AAA			387	501				
54	42	U4AA054042A2645AAA	602		436	550	2730	21		
60	48	U4AA060048A2845AAA	642		476	591	2925			
66	53	U4AA066053A3045AAA	681		509	623	3120	22		
72	57	U4AA072057A3245AAA	842		549	664	3900			
78	62	U4AA078062A4045AAA	921		598	712	4290	23		
84	68	U4AA084068A4445AAA	960		630	745	4485			
90	72	U4AA090072A4645AAA	999		663	777	4680	24		
96	76	U4AA096076A4845AAA	1039		671	785	4875			
108	84	U4AA108084A5245AAA	1079		728	842	5070	25		
120	98	U4AA120098A5645AAA	1157		841	956	5460			
132	106	U4AA132106A6045AAA	1237		1122	1452	5850	29		
138	111	U4AA138111A6445AAA	1315		1163	1493	6240			
144	115	U4AA144115A6445AAA			1195	1525				
150	120	U4AA150120A7845AAA	1696	1236	1566	7605	40			
162	130	U4AA162130A8045AAA	1735	1317	1647	7800				
168	131	U4AA168131A8245AAA	1774	1325	1655	7995	39			
172	140	U4AA172140A8445AAA	1814	1398	1728	8190				
180	144	U4AA180144A8645AAA	1853	1430	1761	8385	42			
192	152	U4AA192152A8845AAA	1893	1495	1826	8580				
198	160	U4AA198160A9245AAA	1971	1560	1890	8970	44			
204	165	U4AA204165A9445AAA	2011	1601	1931	9165				
216	174	U4AA216174AA645AAA	2250	1674	2004	10335	50			
228	180	U4AA228180AB045AAA	2328	1722	2053	10725				
240	190	U4AA240190AB245AAA	2367	1804	2134	10920	49			

Notes:

1. Refer to Figure 4 for illustrations of dimensions B and C and Figure 5 for dimensions A and D.

* Phase-to-Phase clearances are expressed as minimum arrester center-to-center distances. Phase-to-Earth clearances are expressed as minimum arrester centerline-to-ground distances.

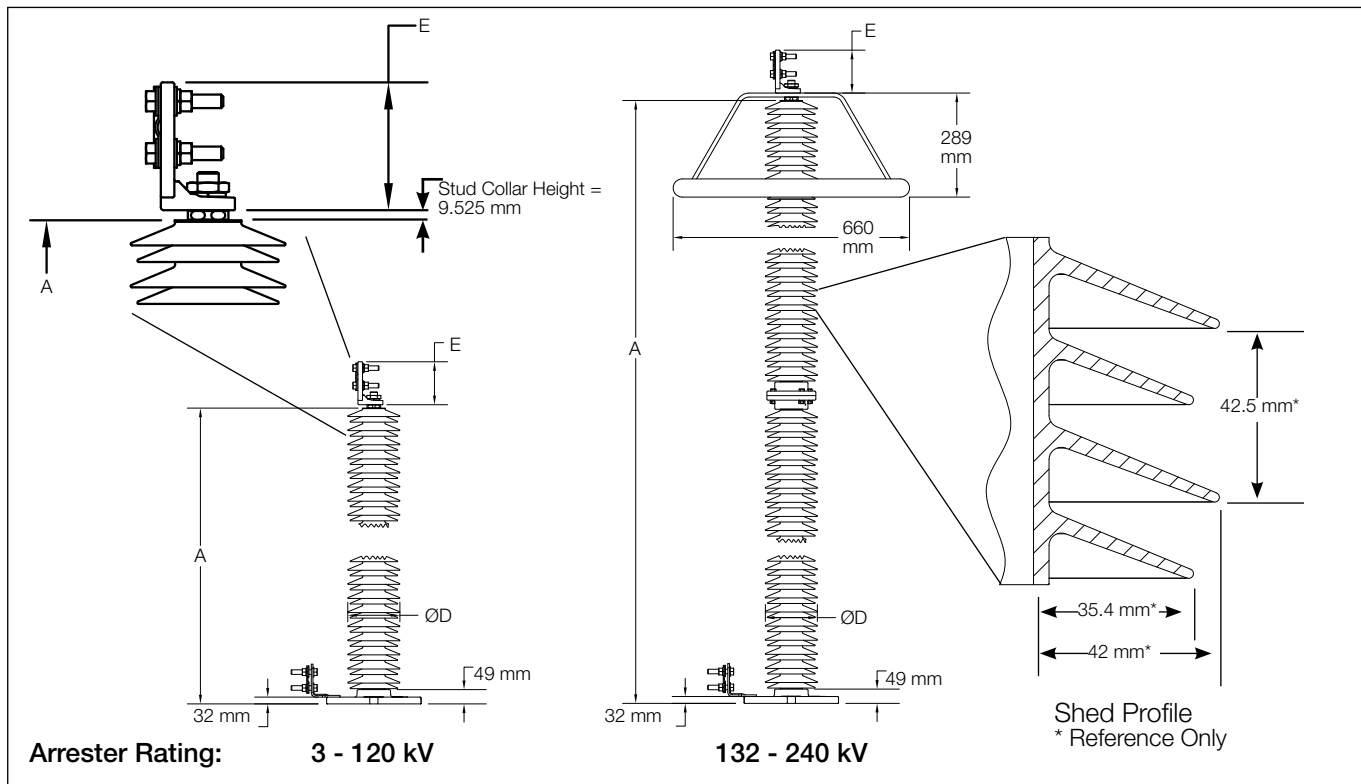

Figure 5.
Outline Drawing of Standard UltraSIL Polymer-Housed VariSTAR Type U4 Surge Arresters.

Notes:

Refer to Table 5 for dimensions A. Arresters shown with standard line and earth terminals.

Outlines in Figure 5 and data from Table 5 represent standard arrester catalog numbers. Outline dimensions will vary when optional housing codes are selected. Consult factory for more information.

Refer to Table 6 for dimensions E.

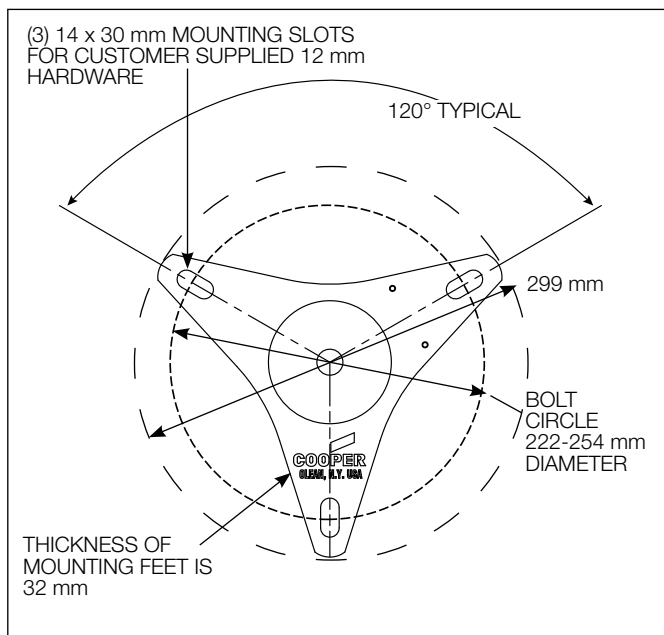

Figure 6.
Base mounting.

TERMINAL OPTION DIMENSIONS

TABLE 6
Terminal Options Dimensions "E"

Catalog Number Digit 14	Description of Line Terminal Option	Dimension (mm)
1	Eyebolt Connector	81
4	NEMA Four-Hole Pad	120
D, H	Cylindrical Stem Connector	156

Note: Refer to Figure 5 for illustration of dimension E.

ISOLATION BASES AND SURGE COUNTERS

TABLE 7
Bases and Counters

Catalog Number	Description of Counters
AM22A1	Counter without Leakage Current Meter
AM22A2	Counter with Leakage Current Meter (0-30 mA)
AM22A3	Counter with Leakage Current Meter (0-50 mA)
AM22A12	AM22A2 with Auxiliary Contact
Description of Bases	
AM23A1	For UI, US, UH, U2, U3, and U4 arresters and AZE-AZG arresters rated 120 kV (single section) or below

TABLE 8
UltraQUIK™ Catalog Numbering System for UltraSIL Polymer-Housed VariSTAR Class 4 Arresters

1	2	3	4	5	6	7	8	9	10	11	12	13	14	15	16	17	18
U	4																

Catalog Number Digits:

1 = "U" (UltraSIL Housed Arrester)

2 = "4" (IEC Class 4 Arrester)

3 = "A" Standard Electrical Build*

* Consult manufacturer for further information regarding alternate electrical builds.

4 = "A" Standard Cantilever Strength Design

5 through 10 = Arrester Rating, U_r (COV, U_c)

003002 = 3 kV (2.55 kV)	042034 = 42 kV (34.0 kV)	132106 = 132 kV (106 kV)
006005 = 6 kV (5.10 kV)	045036 = 45 kV (36.5 kV)	138111 = 138 kV (111 kV)
009007 = 9 kV (7.65 kV)	048039 = 48 kV (39.0 kV)	144115 = 144 kV (115 kV)
010008 = 10 kV (8.4 kV)	054042 = 54 kV (42.0 kV)	150120 = 150 kV (120 kV)
012010 = 12 kV (10.2 kV)	060048 = 60 kV (48.0 kV)	162130 = 162 kV (130 kV)
015012 = 15 kV (12.7 kV)	066053 = 66 kV (53.0 kV)	168131 = 168 kV (131 kV)
018015 = 18 kV (15.3 kV)	072057 = 72 kV (57.0 kV)	172140 = 172 kV (140 kV)
021017 = 21 kV (17.0 kV)	078062 = 78 kV (62.0 kV)	180144 = 180 kV (144 kV)
024019 = 24 kV (19.5 kV)	084068 = 84 kV (68.0 kV)	192152 = 192 kV (152 kV)
027022 = 27 kV (22.0 kV)	090070 = 90 kV (70.0 kV)	198160 = 198 kV (160 kV)
030024 = 30 kV (24.4 kV)	096076 = 96 kV (76.0 kV)	204165 = 204 kV (165 kV)
033027 = 33 kV (27.0 kV)	096077 = 96 kV (77.0 kV)	216174 = 215 kV (174 kV)
036029 = 36 kV (29.0 kV)	108084 = 108 kV (84.0 kV)	228182 = 228 kV (182 kV)
039031 = 39 kV (31.5 kV)	120098 = 120 kV (98.0 kV)	240190 = 240 kV (190 kV)

11 = "A" Standard High Creep Silicone Rubber Housing

TABLE 8 (continued)
UltraQUIK™ Catalog Numbering System for UltraSIL Polymer-Housed VariSTAR Class 4 Arresters

1	U	2	4	3	4	5	6	7	8	9	10	11	12	13	14	15	16	17	18
---	---	---	---	---	---	---	---	---	---	---	----	----	----	----	----	----	----	----	----

12 and 13 = Housing Code (Select from Table below): O = Standard Housing (31 mm/kV)

Leakage Length (mm) / U _r Arrester Rating (kV rms)	08	10	12	14	16	18	22	24	26	28	30	32	40	44	46	48	50	52	56	60*	64*	78*	80*	82*	84*	86*	88*	92*	94*	A6*	B0*	B2*	
3	O																																
6		O																															
9		O																															
10		O																															
12			O																														
15			O																														
18				O																													
21				O																													
24					O																												
27					O																												
30						O																											
33						O																											
36						O																											
39							O																										
42							O																										
45								O																									
48									O																								
54										O																							
60											O																						
66												O																					
72													O																				
78														O																			
84															O																		
90																O																	
96																	O	O															
108																		O															
120																			O														
132																				O													
138																					O												
144																					O												
150																						O											
162																							O										
168																								O									
172																									O								
180																										O							
192																											O						
198																												O					
204																													O				
216																														O			
228																															O		
240																																O	

* Arresters equipped with these housing codes ship with a grading ring.

TABLE 8 (continued)
UltraQUIK Catalog Numbering System for UltraSIL Polymer-Housed VariSTAR Class 4 Arresters (Continued)

1	U	2	4	3	4	5	6	7	8	9	10	11	12	13	14	15	16	17	18
---	---	---	---	---	---	---	---	---	---	---	----	----	----	----	----	----	----	----	----

14 = Line Terminal Options

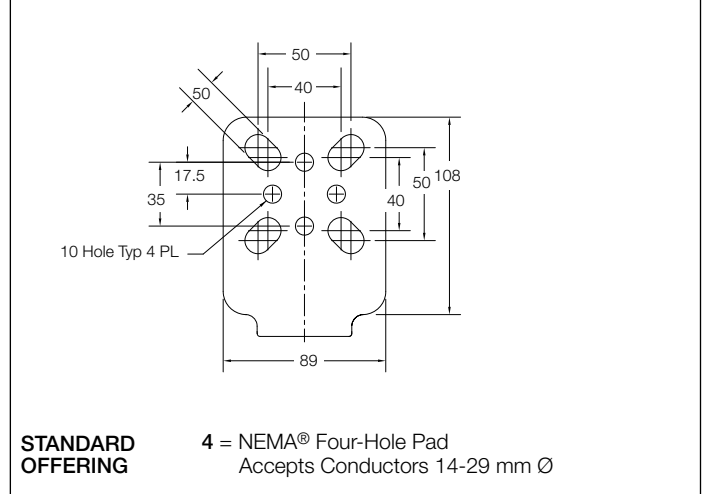
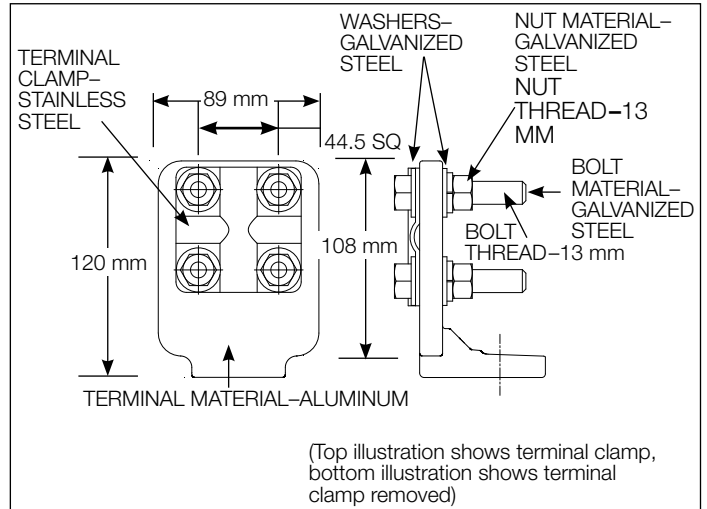
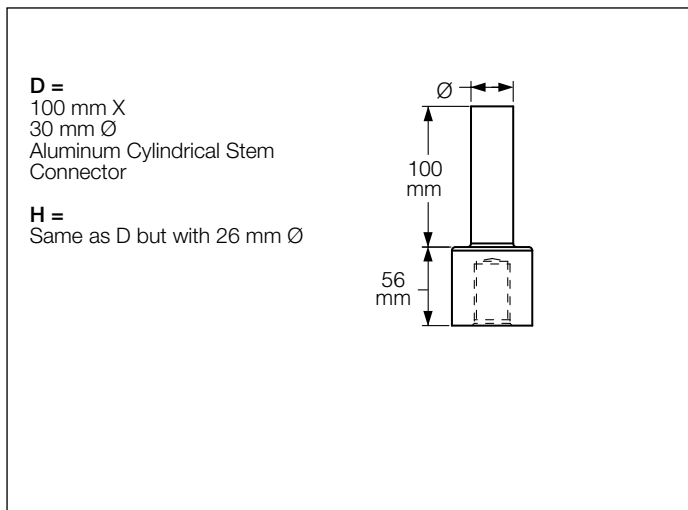
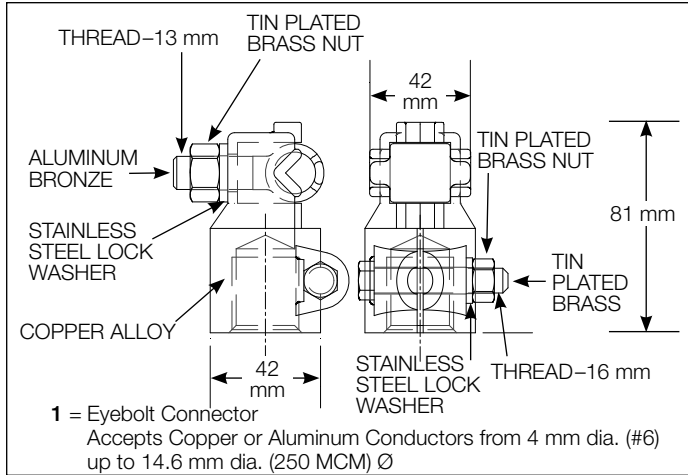
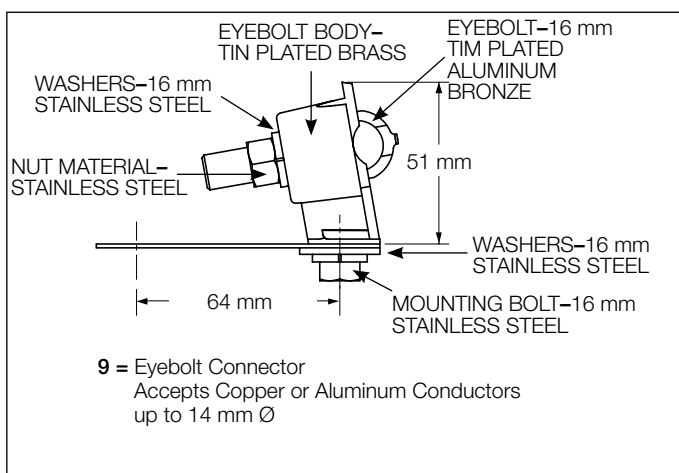
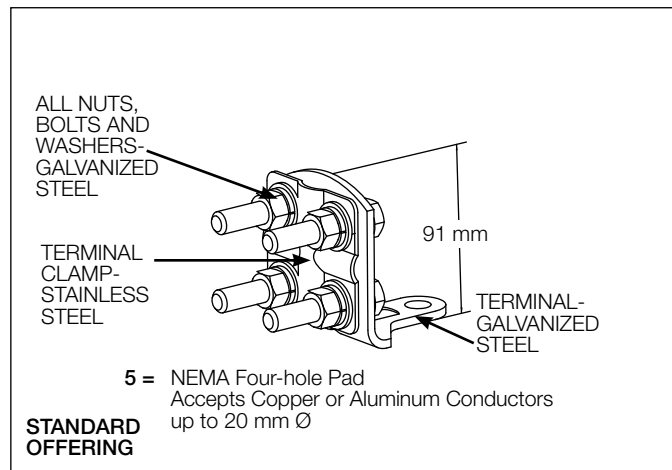
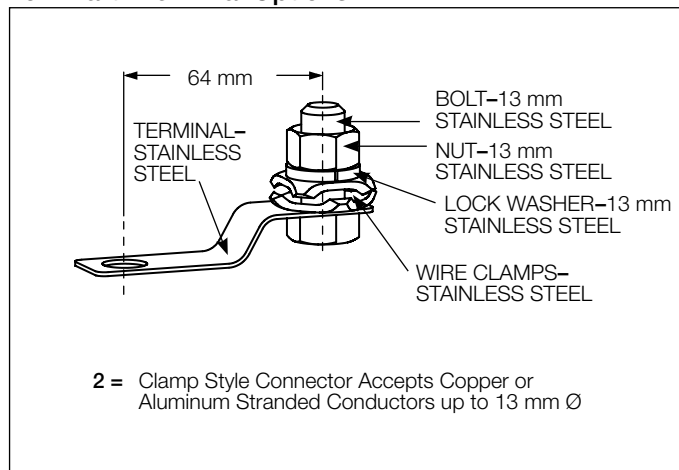

TABLE 8 (continued)
UltraQUIK Catalog Numbering System for UltraSIL Polymer-Housed VariSTAR Class 4 Arresters (Continued)

1	U	2	4	3	4	5	6	7	8	9	10	11	12	13	14	15	16	17	18
---	---	---	---	---	---	---	---	---	---	---	----	----	----	----	----	----	----	----	----

15 = Earth Terminal Options



16 = Mounting Arrangement

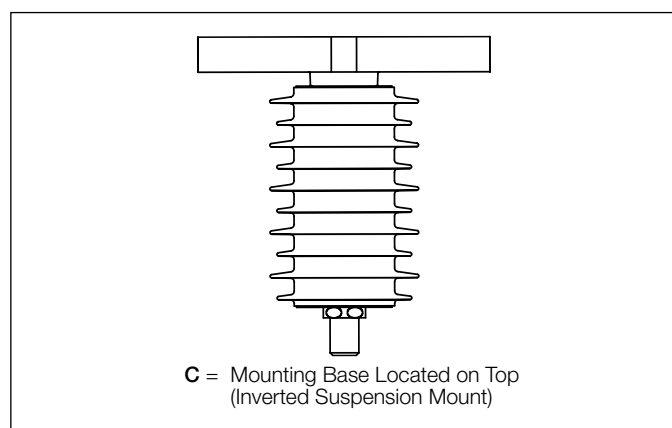
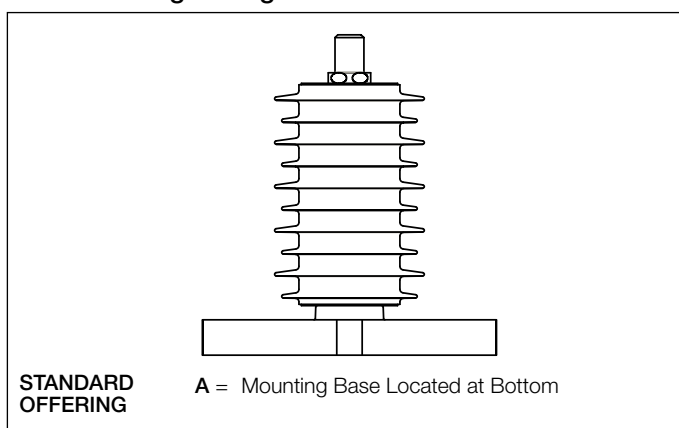

TABLE 8 (continued)

UltraQUIK Catalog Numbering System for UltraSIL Polymer-Housed VariSTAR Class 4 Arresters (Continued)

1	U	2	4	3	4	5	6	7	8	9	10	11	12	13	14	15	16	17	18
---	---	---	---	---	---	---	---	---	---	---	----	----	----	----	----	----	----	----	----

17 = Nameplate Information, See Figures 7 and 8

Nameplate information is per IEC 60099-4 and is available in the following languages.

Specify:

A = English B = Spanish C = Portuguese

18 = Packaging

Arresters with housing codes 60 or less are shipped complete, ready for installation. Arresters with housing codes greater than 60 are shipped unassembled, requiring assembly during installation.

- A = Export packing, cardboard
- 2 = Export packing, wood crating

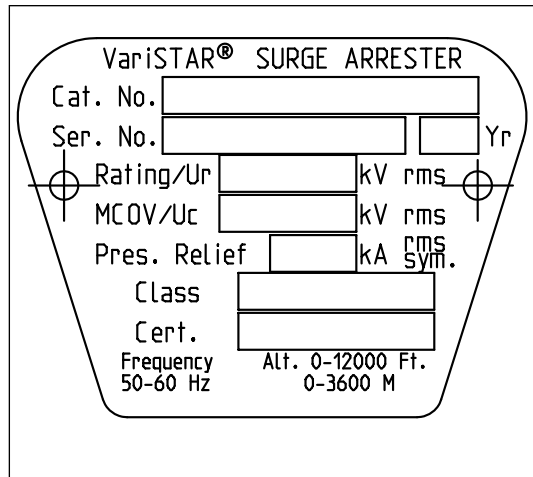

Figure 7. Arrester base nameplate (English version).

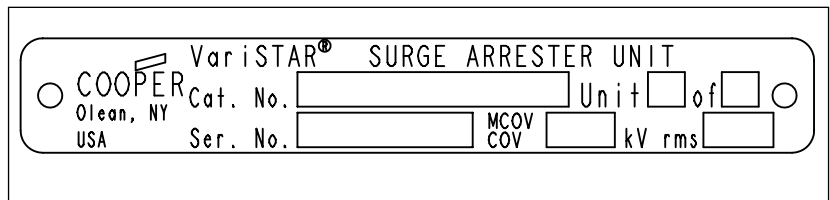

Figure 8. Detail of unit nameplate on arrester base.

NAMEPLATE INFORMATION

A stainless steel nameplate is attached to the base of every UltraSIL Polymer-Housed Type U4 Arrester. The arrester catalog number, serial number, year of manufacture, Ur, Uc, and pressure relief rating are among the details provided on the nameplate. See Figure 7 for an example of a base nameplate. For multi-unit arresters an additional nameplate is provided on the base as shown in Figure 8.

ADDITIONAL INFORMATION

- I235-98 UltraSIL Polymer-Housed VariSTAR Type U3 Surge Arrester for Systems through 275 kV IEC 10-kA; Line Discharge Class 3
- IS235-97-1 UltraSIL Polymer-Housed VariSTAR Types U3/U4 Surge Arresters Installation and Maintenance Instructions
- CP1302 10 kA Class 4 Certified Test Report IEC 60099-4 2009

© 2013 Cooper Industries. All Rights Reserved. Cooper Power Systems, VariSTAR, UltraSIL and UltraQUIK are valuable trademarks of Cooper Industries in the U.S. and other countries. You are not permitted to use the Cooper Trademarks without the prior written consent of Cooper Industries.