

***Testing has never been as simple,
quick and intuitive***

**MULTI-FUNCTION
INSTALLATION
TESTER**



**THE ALL-
IN-ONE
electrical
installation
tester**

**PERFORMANCE
DESIGN AND ERGONOMICS
SPEED AND ACCURACY**

- Installation testing according to the international standards (IEC 60364-6, NF C 15-100, VDE 100, XP C 16-600, etc.)
- Quick operation and simple access to measurements
- User-friendly with its extra-wide backlit graphic screen
- Excellent measurement stability, including in industrial environments affected by disturbances
- Simple, reliable connections
- Contextual help for each function
- Suitable for all types of neutral systems (TT, TN, IT)
- Customized, hierarchical storage of measurement results

**RESIDENTIAL
INDUSTRY
TERTIARY**

Rugged, compact and lightweight, **the C.A 6116 tester** is specially designed for quick and effective learning.

Its large backlit graphic screen is particularly easy to read.

A rotary switch on the instrument's front panel gives direct access to all the functions. A large number of audio signals and visual symbols facilitate quick interpretation of the results in accordance with the standards.

The colour-coded terminals simplify connection.

A neck-strap is also provided for "hands-free" use.



Wide graphic screen for excellent legibility and simple navigation within the instrument

DISPLAY

The display allows you to view all the essential results at a glance.

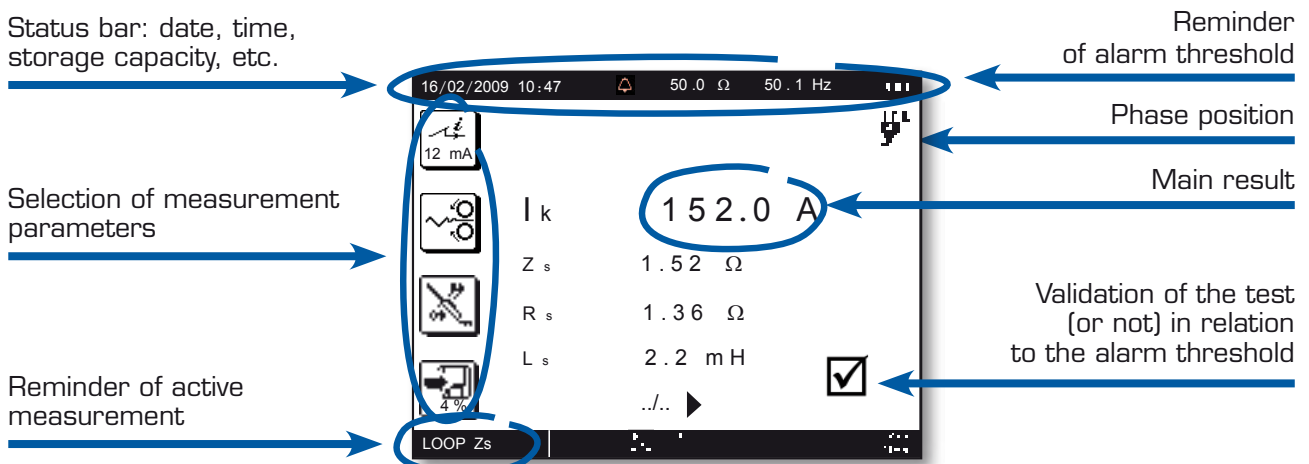

MULTIPLE APPLICATIONS

In domestic, tertiary or industrial environments, the **C.A 6116** can be used to check an electrical installation's compliance with the applicable standards.

This verification is mandatory to ensure that the installation is not at all hazardous, whatever the type of building tested (domestic, public, industrial, etc.). The **C.A 6116** is ideal for electricians and certification organizations involved in:

- initial electrical testing of a new installation
- electrical testing after renovation
- periodic testing of an installation
- maintenance and troubleshooting on an installation

The **C.A 6116** can be used to carry out all the measurements stipulated by the European standards on electrical installations simply and without any risk of error.

In addition, it complies with the brand new international **EN/IEC 61557** regulations which require a high level of performance from installation testing instruments.



EFFECTIVE CONTEXTUAL HELP & GUARANTEED SAFETY

The **C.A 6116** includes **clear, detailed contextual help**.

This makes it ideal for both experts and less experienced users.

Dedicated help is available for each type of measurement, providing guidance for the connections to be set up as well as assistance in interpreting the results.

For greater safety, if the instrument is connected incorrectly or if a dangerous voltage is present, an error message is displayed to warn the user.

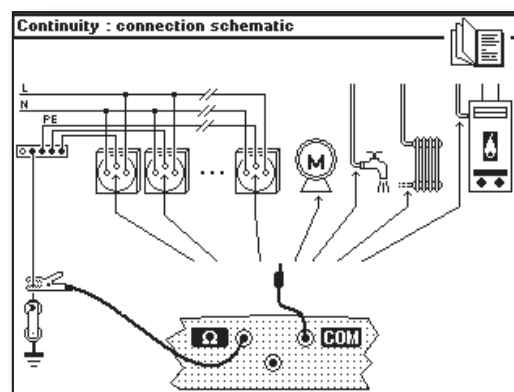

MULTIPLE APPLICATIONS

CONTINUITY

The purpose of this measurement is to check the resistance of the earth conductor (PE) which drains fault currents to the earth. This resistance must be less than a threshold specified by the standard applicable to the installation tested, which is usually 2Ω as indicated at the top of the screen.

As required by the standards, the C.A 6116 carries out the measurement with a minimum current of **200 mA** and a no-load voltage of 4 to 24 V.

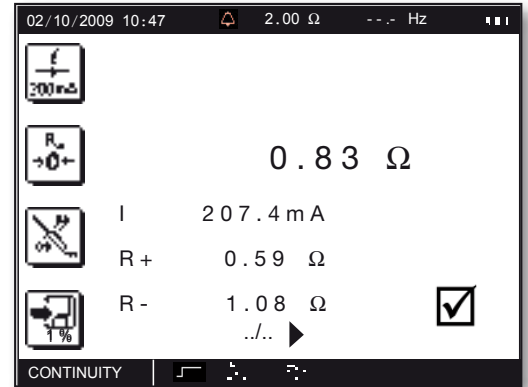

INSULATION

This measurement can be used to check that the insulation resistance is greater than a minimum value specified in the installation standards (insulation measured between active conductors and between an active conductor and the earth).

The C.A 6116 proposes 5 different test voltages: 50/100/250/500/1,000 V, so that it can adapt to all types of installations (ELV, low-current installation, residential, industrial).

By default, insulation measurement is carried out at 500 V with an alarm at $0.5 M\Omega$.

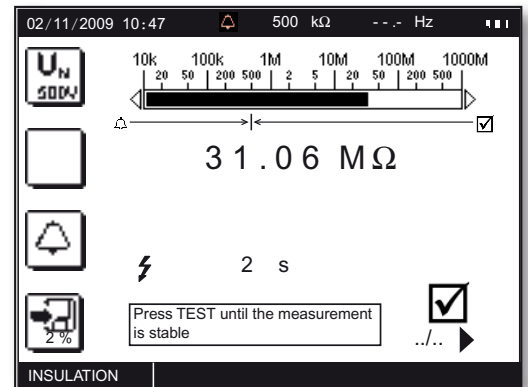

EARTH MEASUREMENT

Correct earthing ensures that people are kept safe and also protects property and installations in the event of lightning or fault currents. It must always be accompanied by a cut-off device.

There are many ways of setting up earth measurements and the right choice depends on:

- the type of neutral system
- the type of installation (residential, industrial, urban, rural, etc.)
- the possibility of shutting off the power.

The C.A 6116 can be used for all the types of earth measurements: on installations with the power on or off and with or without stakes.

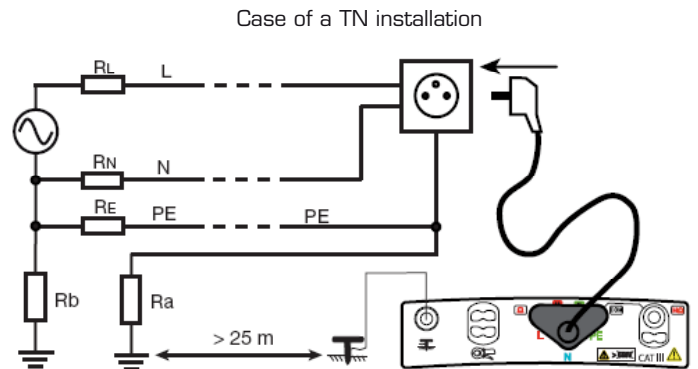

3P EARTH

3-pole earth measurement using 2 auxiliary stakes (also known as the 62% method) is the reference earth measurement, providing a precise earth resistance value. As it is carried out with the power off, this is the only type of earth measurement applicable to an installation which has not yet been connected to the electrical power distribution network or is no longer connected to it.

Once the cables have been connected, it is very simple to implement. All you have to do is set the rotary switch to RE 3P, press the Test key and read the result.

The user can choose between two test modes: quick test or expert mode.

In expert mode, the resistance of the auxiliary stakes, RS and RH, is also measured.

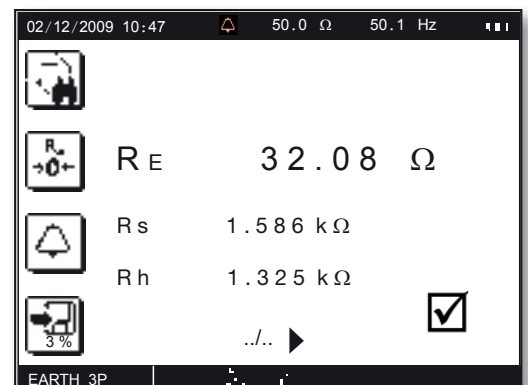

EARTH MEASUREMENT WITH POWER ON (Ra)

Equivalent to 3P earth measurement, power-on earth measurement can save considerable time: it does not require disconnection of the earth bar and only a single auxiliary stake (S) is needed. In addition, this method guarantees safety for the equipment and people in contact with the electrical installation because the earth is not disconnected.

Two modes are available:

- Measurement without tripping with a low current (6, 9 or 12 mA) for installations protected by a 30 mA residual current device (RCD),
- Measurement with a high current (TRIP mode) providing greater measurement accuracy. It is then possible to calculate the fault voltage (Ufk) in the event of a line-earth short-circuit, as defined by the SEV 3755 standard.

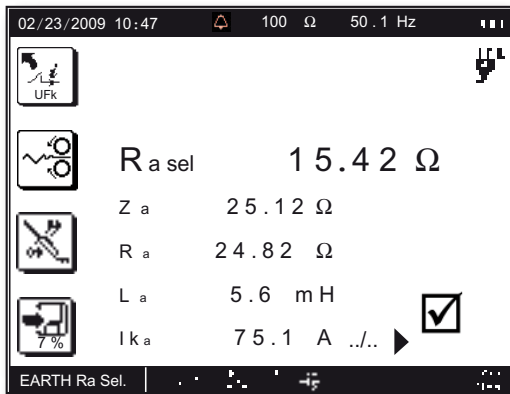

SELECTIVE EARTH MEASUREMENT WITH POWER ON (Ra Sel.)

If there is an earthing system comprising several earths in parallel (TN-type installation), it is possible to use a clamp-on ammeter (available as an option) for selective earth measurement with the power on. This power-on selective earth measurement function allows you to choose one of the parallel earths and find out its precise value without disconnecting from the rest of the earth network.

To guarantee high measurement accuracy, this "Ra Sel" measurement is only available in TRIP mode (high-current mode), so it is not possible to modify the test current for this measurement.

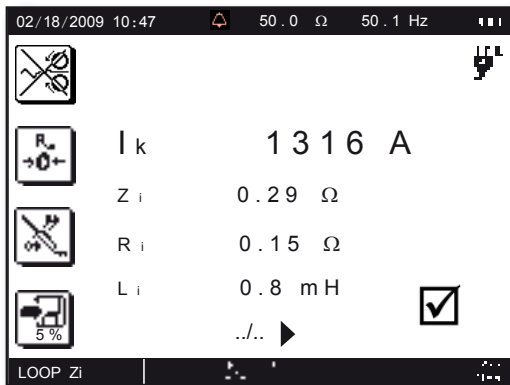

LINE IMPEDANCE (Zi)

The Zi measurement represents the impedance of the Line-Neutral loop (L-N) or the loop between phases (L-L) and can be used to calculate the short-circuit current in order to check the protective systems on the installation (fuse or RCD).

This measurement is carried out in TRIP mode (high current) to ensure satisfactory measurement accuracy.

The connection can be made either with the three-pin mains connector or with separate leads for measurements on electrical cabinets.

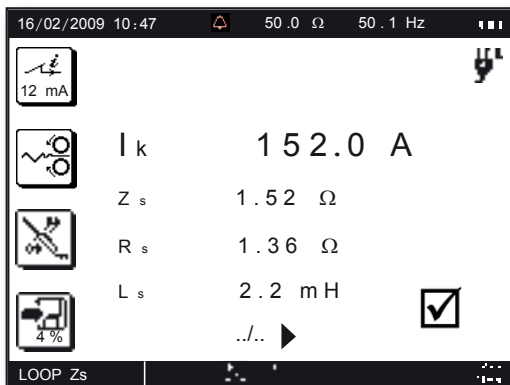

LOOP IMPEDANCE (Zs)...

The Zs measurement represents the impedance of the Line-Earth loop (L-PE). With this measurement, it is possible to:

- gain an indication of the earth value on TT-type installations quickly and easily without setting up any stakes
- calculate the short-circuit current and determine the correct size for the RCD on a TN-type installation.

This type of measurement is not possible however on an IT-type installation because of the high earthing impedance of the power supply transformer or even its total insulation in relation to the earth.

By default, the Zs loop measurement is carried out without tripping the 30 mA RCDs (test current = 12 mA) with a 100 Ω alarm threshold. In addition, the Zs position of the switch also offers power-on earth measurement functions (Ra and Ra Sel) thanks to automatic detection of the auxiliary stake (S) and the clamp-on ammeter.

...LOOP IMPEDANCE (Z_s)

As well as the default 12 mA measurement mode, the instrument also includes:

- a mode without tripping using a 6 mA or 9 mA current so that you can guarantee the RCDs will not be tripped on installations with high fault currents.
- a high-current mode (TRIP) for more precise measurement.

For calculation of the short-circuit current I_k , the **C.A 6116** allows you to choose the reference voltage U_{ref} : the voltage measured (ULN), the voltage stipulated by the previous standard (220 V) or the voltage stipulated by the new standard (230 V).

RESIDUAL CURRENT DEVICE TEST

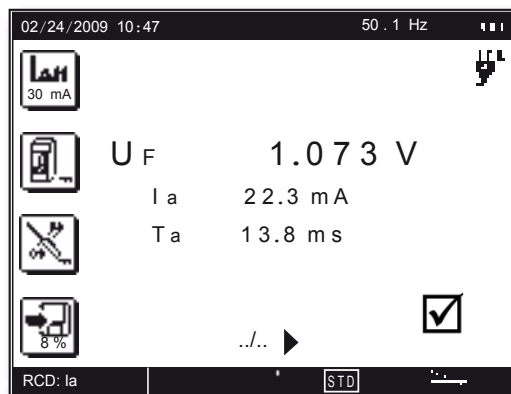

The **C.A 6116** can be used for 3 types of test:

- a test in pulse mode: measurement of tripping time
- a test in step mode: measurement of tripping time and the precise value of the tripping current.
- a test without tripping: to check that the RCD is not tripped when the leakage current is lower than the tripping threshold, i.e. $I_{\Delta n}/2$.

The RCD test can also be used to calculate the fault voltage U_f , such that:
 $U_f = Z_s \times I_{\Delta n}$

To perform this test in Step mode, the switch must be set to $I_{\Delta n}$.

In pulse mode, the switch must be set to Δt .

Various characteristics can be parameterized for this measurement:

- Rating of the RCD tested
- RCD type: STD (standard), S or G (models only tested with a current of $2 I_{\Delta n}$)
- Waveform of test signal
- Activation/deactivation of Volt Beeper in Step mode
- Activation/deactivation of the alarms in Pulse mode

POWER & HARMONICS

The **C.A 6116** can be used for power measurements, which are particularly useful for first-level analysis of the energy quality on the installation concerned.

Power measurement can be selected by setting the switch to W. It is then possible to view the corresponding voltage and current curves.

The **C.A 6116** measures and displays harmonics up to the 50th order.

The THD-F and voltage values are displayed simultaneously, along with the name of the frequency line selected and its amplitude.

In this mode, users can choose an FFT analysis on the voltage or current and display a linear or logarithmic scale.

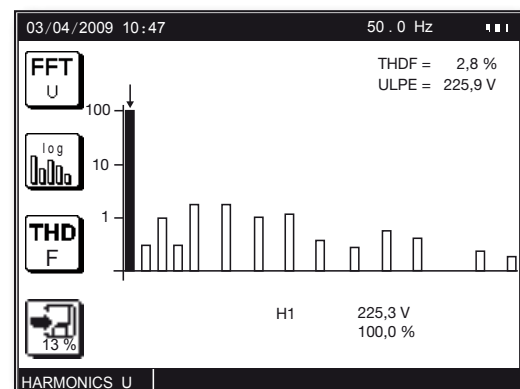

ICT SOFTWARE

The ICT software, developed specifically for installation testers, can be used for quick, simple analysis of the measurements recorded by the **C.A 6116**.

Delivered as standard with the tester, it offers the following functions:

- Data recovery
- Parameterization of the instrument
- Customization of measurement campaigns with transfer into the instrument
- Printing of reports

Example 1:

On the left-hand side of the screen, the menu presents the tree structure of the data present in the product and measurement campaigns, clearly identified (customer, location, type of measurements, etc.). The part displayed as a zoom corresponds to the test carried out. It indicates the result of the main measurement. Whatever the test, the result (in this case, OK) is displayed clearly.

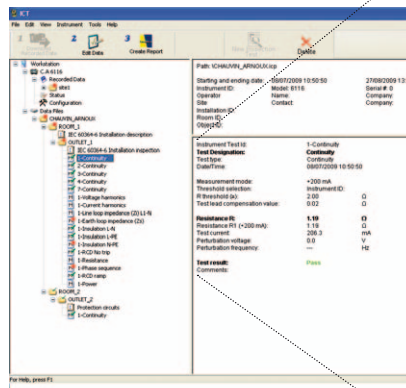

DATAVIEW® SOFTWARE

The measurements made with the **C.A 6116** can also be processed with the DataView® multi-product expert processing software.

DataView® automatically recognizes the instrument when it is connected to the PC and opens the corresponding menu.

The menu, in tree form, offers users direct access to the data recorded in the instrument, its configuration, etc.

DataView® includes a large number of report templates for quick printing in full compliance with the applicable standards.

Users can also create their own templates, as required.

Instrument Test Id:	1-Continuity
Test Designation:	Continuity
Test type:	Continuity
Date/Time:	08/07/2009 10:50:50
Measurement mode:	+200 mA
Threshold selection:	Instrument ID:
R threshold (≥):	2.00 Ω
Test lead compensation value:	0.02 Ω
Resistance R:	1.19 Ω
Resistance R1 (+200 mA):	1.19 Ω
Test current:	206.3 mA
Perturbation voltage:	0.0 V
Perturbation frequency:	--- Hz
Test result:	Pass
Comments:	

Example 2:

Tree structure of a measurement campaign

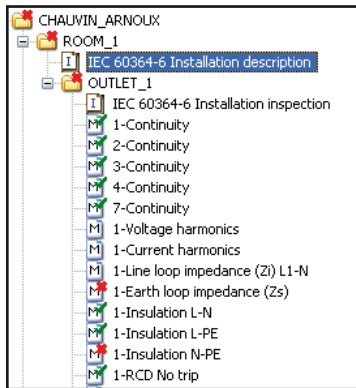

Example 3:

Production of a report according to the IEC 60364-6 standard

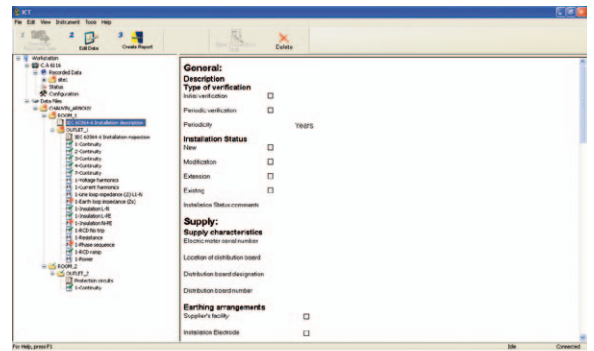

ACCESSORIES

The **C.A 6116** is supplied with a large number of accessories: safety leads, three-pin/mains lead or three-pin/safety leads, test probes, crocodile clips, etc.

Delivered in a carrying bag, the standard version also includes a wrist strap and 4-point strap for "hands-free" use.

Complete earth kit (option)



USB connection cable



Remote control probe



Mains power pack for quick charging



Reinforced bag



TECHNICAL SPECIFICATIONS

INSULATION

Rated voltage	U _{test} : 50 / 100 / 250 / 500 / 1000 V DC
Range / Resolution / Accuracy	0.01 MΩ to 2 GΩ / 1 kΩ to 1 MΩ / ±(5 % of measurement + 3 cts)

EARTH

3P EARTH	
Range / Resolution / Accuracy	0.50 to 4 kΩ / 0.01 Ω to 1 Ω / ±(2 % of measurement + 2 cts)
Others	Auxiliary stake resistance measurement (up, to 40 kΩ)

EARTH WITH POWER ON

Installation voltage / Frequency	90 to 550 V / 15.3 to 17.5 Hz - 45 to 65 Hz
----------------------------------	---

1P EARTH

High-current mode with tripping (TRIP)	Test current: 5 A
Range / Resolution / Accuracy	0.10 Ω to 3,999 Ω / 0.01 Ω to 1 Ω / ±(5 % of measurement + 2 cts)
Mode without tripping (NO TRIP)	Test current: 6 mA - 9 mA - 12 mA (by default)
Range / Resolution / Accuracy	0.20 Ω to 3,999 Ω / 0.01 Ω to 1 Ω / ±(5 % of measurement + 3 cts)

1P SELECTIVE EARTH

Range / Resolution / Accuracy	0.20 Ω to 3,999 Ω / 0.01 Ω to 1 Ω / ±(10 % of measurement + 10 cts)
-------------------------------	---

RCDs

Installation voltage / Frequency	90 V to 550 V / 15.3 Hz to 17.5 Hz / 45 Hz to 65 Hz
I _{Δn}	10/30/100/300/500/650/1,000 mA or variable - Test in step and pulse modes
No-trip test	at ½I _{Δn} - Duration: 1,000 ms or 2,000 ms
Measurement of tripping time	at ½I _{Δn} / 2 I _{Δn} (selective) / 5 I _{Δn}
Step mode	0.3 I _{Δn} to 1.06 I _{Δn} in steps of 3.3 % I _{Δn}

CONTINUITY

Test voltage / I rated	9.5 VDC / I > 200 mA up to 39.99 Ω and 12 mA up to 399.9 kΩ with buzzer
Range / Resolution / Accuracy	0 Ω to 399.9 kΩ / 0.01 Ω to 100 Ω / ±(1.5 % of measurement + 2 cts)

LOOP IMPEDANCE (Z_i and Z_s)

High-current mode with tripping (TRIP)	Test current: 5 A
Range / Resolution / Accuracy	0.1 Ω to 4,000 Ω / 0.01 Ω to 1 Ω / ± (10 % of measurement + 5 cts)
NO TRIP mode (Z _s only)	Test current: 6 mA - 9 mA - 12 mA (by default)
Range / Resolution / Accuracy	0.2 Ω to 4,000 Ω / 0.01 Ω to 1 Ω / ± (10 % of measurement + 5 cts)
Calculation of short-circuit current	0.1 A to 40 kA
Other	Measurement of the resistive and inductive components of the impedances Z _s and Z _i

CURRENT

5 mA to 19.99 A (MN77 clamp) / 5 mA to 19.99 A (C177 clamp) / 20 mA to 200 A (C177A clamp)
Current measurement from 1 mA available with MN77 & C177 by connecting voltage on the product

VOLTAGE

0 to 550 V AC/DC

FREQUENCY

DC / 15.3 to 500 Hz

ACTIVE POWER

0 to 110 kW single-phase - 0 to 330 kW three-phase
Simultaneous display of of voltage and current waveforms.

HARMONICS

Voltage and current harmonics / Orders 0 to 50 / THD

PHASE ROTATION

20 to 550 VAC

GENERAL SPECIFICATIONS

Display	Large 5.7" backlit graphic screen, 320 x 240 counts
Memory / Communication	via USB for data transfer and report creation
Power supply	Rechargeable battery
Dimensions / weight	280 x 190 x 128 mm / 2.4 kg
Protection rating	IP 53
Electrical safety	IEC 61010-1 - 600 V CAT III - IEC 61557

STATE AT DELIVERY

C.A 6116 tester delivered with 1 USB cable, 1 three-pin/mains lead, 1 three-pin lead / 3 safety leads, 3 test probes (Ø 4 mm), 3 crocodile clips, 2 straight/elbowed safety leads (3 m), remote-control probe, mains power pack, wrist strap, 4-point strap for extra comfort, carrying bag, data export software, 5 safety connectors and 5 operating manuals (1 per language).



TO ORDER

C.A 6116 (EURO version)	P01145450	C.A 6116 (CH version).....	P01145450C
C.A 6116 (GB version).....	P01145450A	C.A 6116 (US version).....	P01145450D
C.A 6116 (IT version)	P01145450B		

ACCESSORIES

15 m earth kit (red / blue / green)	P01102017	DataView	P01102095
50 m earth kit	P01102021	Battery pack	P01296024
100 m earth kit	P01102022	USB lead	P01295293
1P 30 m black earth kit	P01102018	PA 30 W mains power pack ...	P01102057
C177 clamp	P01120335	Screen-protection film	P01102094
C177A clamp	P01120336	4-point strap.....	P01298073
MN77 earth kit	P01120460	Carrying bag.....	P01298056
Continuity pole	P01102084		

For assistance and ordering