

# AIS750 Series Alarm Annunciator



Unparallel, modular, multipoint design with Integrated controllers

Two Operation Modes (Stand-alone & Modbus)

All sizes configurable up to 440 Alarm Points

RS485 / RS232 Serial Communication

Manual & software field configurable

Full function, flexible and reliable

Alarm sequence to ISA-S18.1

Five different cell sizes

Nine different output types

Optional bi-colour windows

Individual channel Repeat Relay

Shallow installed depth (145mm)

Integral or remote control pushbuttons

Backlit Illumination by LED modules in different colours

Field selectable Input setting (NC or NO, Dry or Voltage)

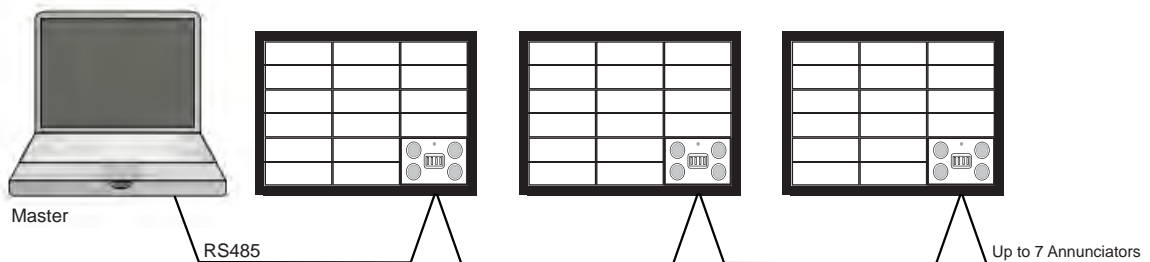



# AIS750 Series Alarm Annunciator

## Inputs

All inputs are optically isolated. System accepts NO/NC, Dry Contact/Voltage (configurable by jumper settings for each alarm point). Option of voltage input from field, PLC or personal computer can be supplied with contact voltages of 24, 48, 125 and 250V (AC or DC).

### Isolation and Polarity:

- Each input is optically isolated up to 2000VAC
- All inputs are bipolar and can accept AC or DC voltages

### Alarm Inputs:

- Wet (voltage supplied) or dry (voltage free) contacts. Field Selectable for each individual channel
- Normally Open (NO) or Normally Close (NC). Field Selectable for each individual channel
- Dry Contact and 24V(DC or AC) are standard inputs and other voltages are optional as bellow
- Other input Voltages; 48V,125V and 250V (DC or AC)

### Response Time:

- Standard unit: 25ms milliseconds
- Made to order from 1ms to 2s

## Field Selectable Parameters

A vast range of system parameters are available to be configured by user, such as; alarm sequence, individual input type (dry contact/voltage), alarm group (critical/non critical), repeat relay setting, ...

There are two options to configure these parameters;

- By DIP switches (in Stand-alone mode)
- Through ALCON software (Modbus mode)

## Communication

### Protocol:

Modbus RTU Slave - Function 02

### Communication port:

RS485/RS232

## Auxiliary Relay (Repeat Relay)

Each alarm point can be supplied with an individual repeat relay. The repeat relays can be set to follow Input or Output. NO and NC contacts are available for each repeat relay.

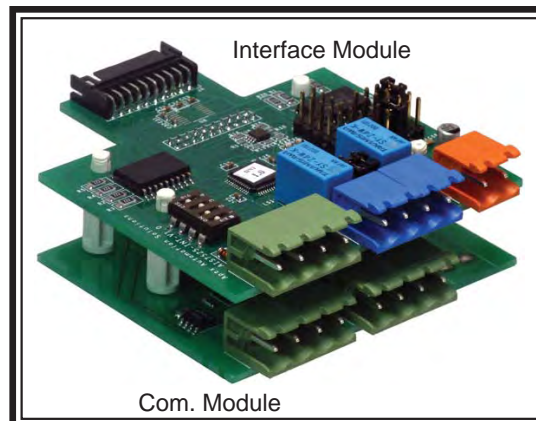
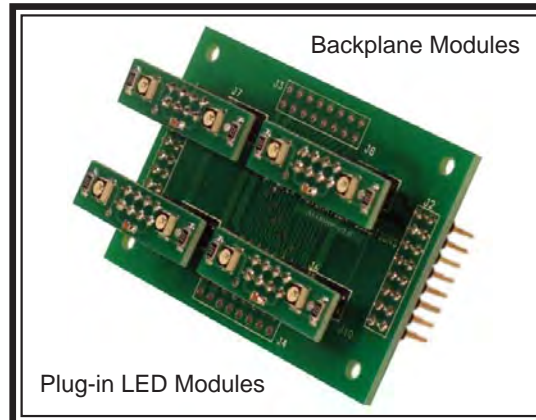
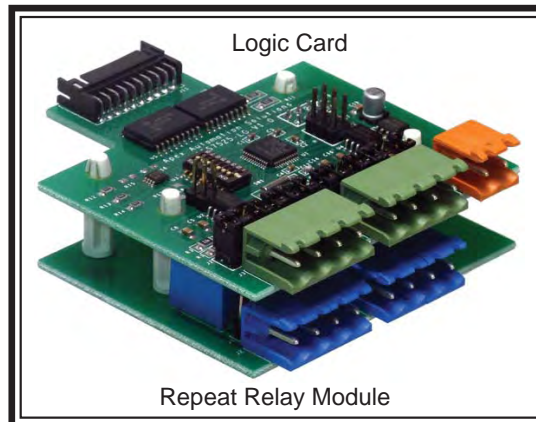

## Outputs

### Supported outputs:

- Light Output
- Critical Audible Relay
- Non-critical Audible Relay
- Critical/Non-critical Buzzer
- Group Relay
- Common Relay
- Auxiliary (Repeat) Relay (can be set to follow Input or Output)
- Common Alarm Relay
- First-up Relay

Relay Rating: - 1A@24VDC  
- 0.5A@ 120VAC

## Alarm Sequences

System supports all *ISA-S18.1/1979 (R1985)* sequences including:

- Manual Reset (M)
- Automatic Reset (A)
- Automatic Reset First Out (F3A)
- Automatic Reset First Out (F1A)
- Manual Reset First Out (F2M-1)
- Ringback (R)
- No Lock In

These sequences are Field Selectable for each Alarm Controller. For example for H21 window type, two channels have the same sequence.

## Multi-drop Connection

Multi-drop RS485 communication is available as an option.

Up to 7 Annunciators can be connected together and to other devices.

Each character represents 8 bit binary data in hexadecimal format. All characters are framed with No Parity bit and one stop bit.

Visit

[www.annunciator.ca](http://www.annunciator.ca)  
for updated specification

# AIS750 Series Alarm Annunciator

## Window/Cell Configuration

The AIS750 is modular and window based designed. It is manufactured from 75x50mm windows which can be assembled in an array to provide the number of rows and columns required to suit individual panel designs. Each cell within the annunciator is able to contain either;

- One single large window (H11 type): 75x50mm (WxH)
- Two medium cells: (H21 type): 75x25mm (WxH)  
(H12 type): 37.5x50mm (WxH)
- Four small cells: (V21 type): 50x37.5mm (WxH)  
(H44 type): 37.5x25mm (WxH)

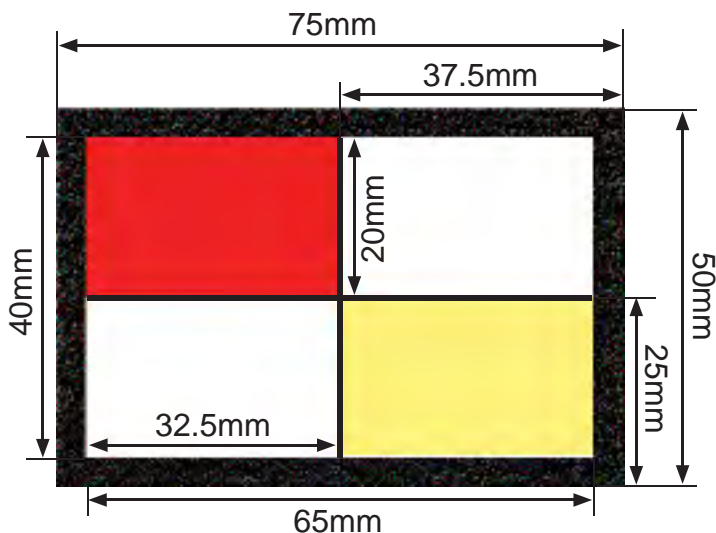

Calculation of overall and cutout sizes is very easy by using the following formulas:

Overall Size Calculation of H11, H21, H12 and H44:

Width (mm) =  $C \times 75 + 37 \pm 0.5$

Height (mm) =  $R \times 50 + 37 \pm 0.5$

Cutout Size Calculation of H11, H21, H12 and H44:

Width (mm) =  $C \times 75 + 33 \pm 0.5$

Height (mm) =  $R \times 50 + 33 \pm 0.5$

Overall Size Calculation of V21:

Width (mm) =  $C \times 50 + 37 \pm 0.5$

Height (mm) =  $R \times 75 + 37 \pm 0.5$

Cutout Size Calculation of V21:

Width (mm) =  $C \times 50 + 33 \pm 0.5$

Height (mm) =  $R \times 75 + 33 \pm 0.5$

Visit the bellow link for Lens Replacement demonstration

<http://www.youtube.com/watch?v=Hfd0D7UofgM>

**C: Number of 75x50mm Windows in one row**

**R: Number of 75x50mm Windows in one column**

# AIS750 Series Alarm Annunciator

## Alarm Sequences

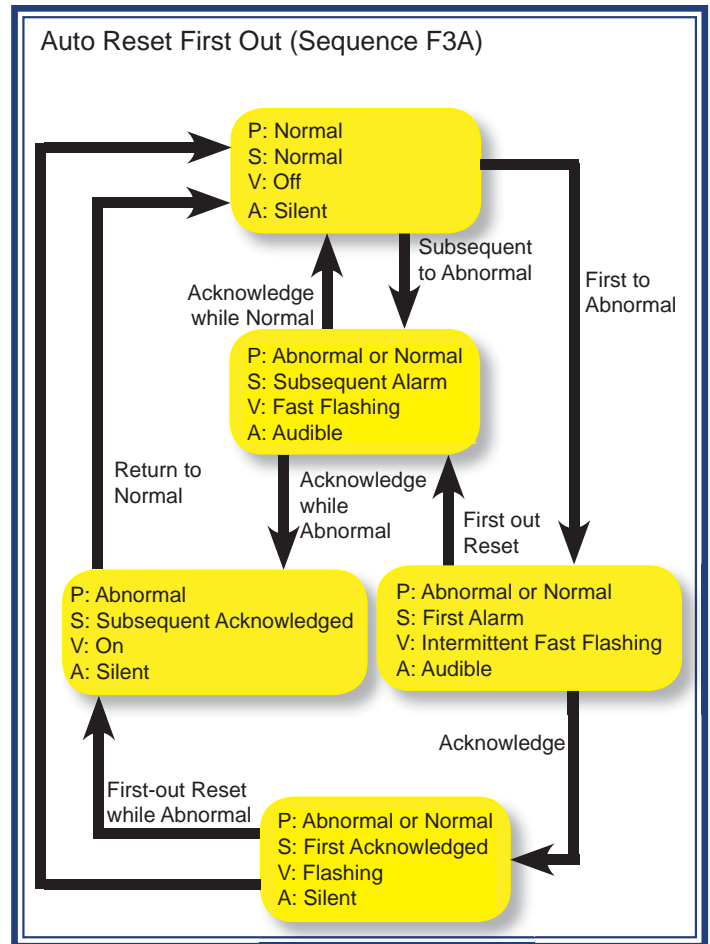
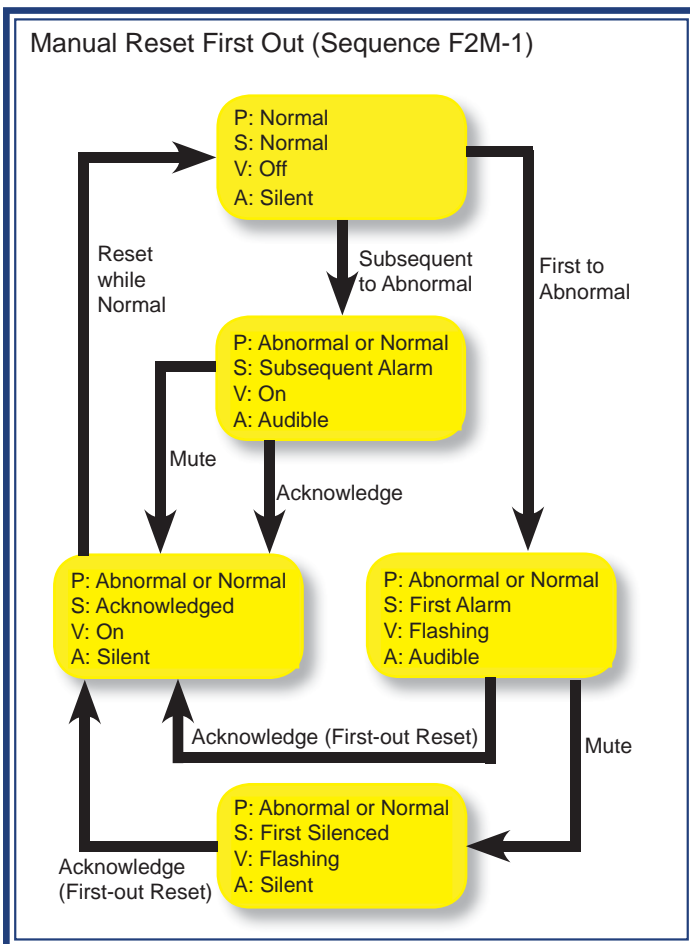
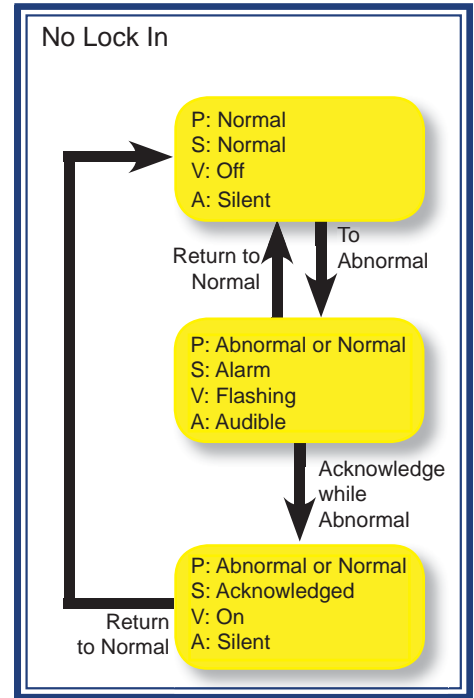
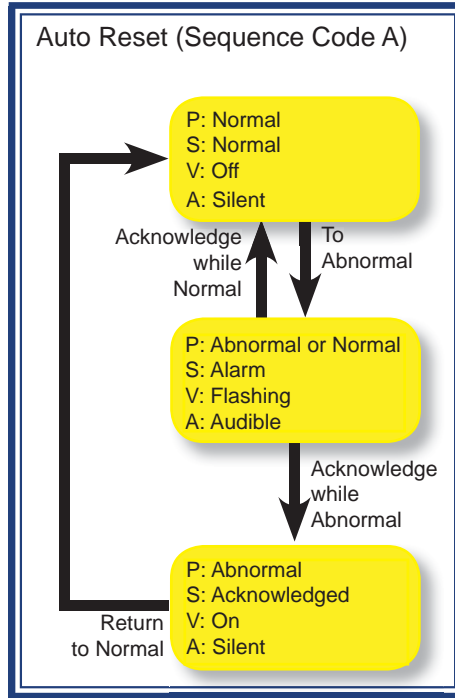
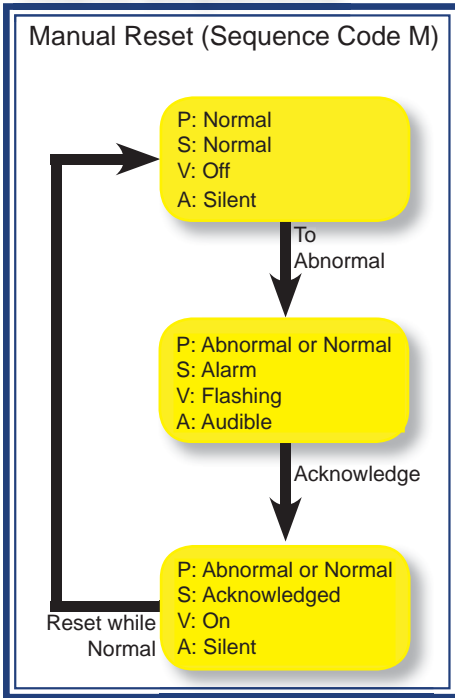

### Legends:

P: Process    S: Sequence    V: Visual    A: Audible    AA: Alarm Audible    RA: Ringback Audible

# AIS750 Series Alarm Annunciator

## Alarm Sequences

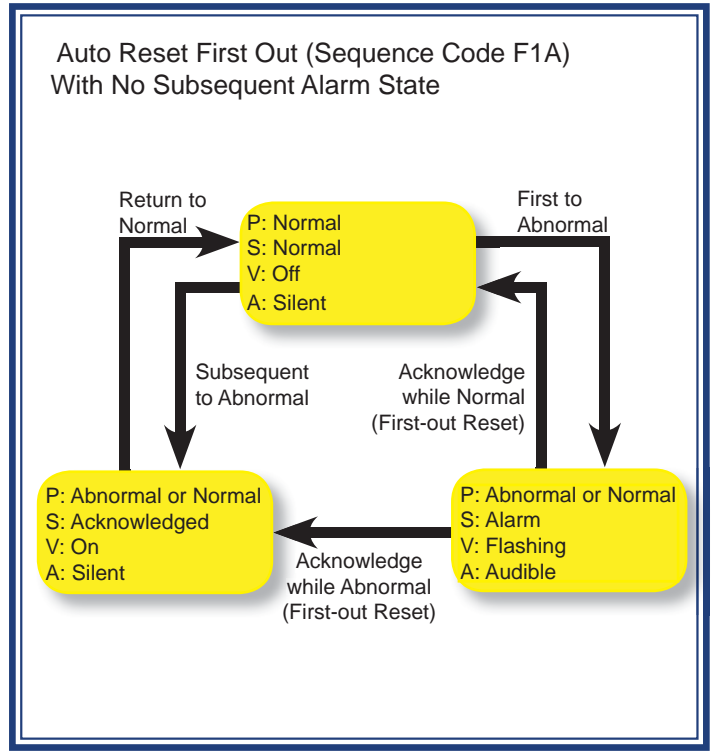
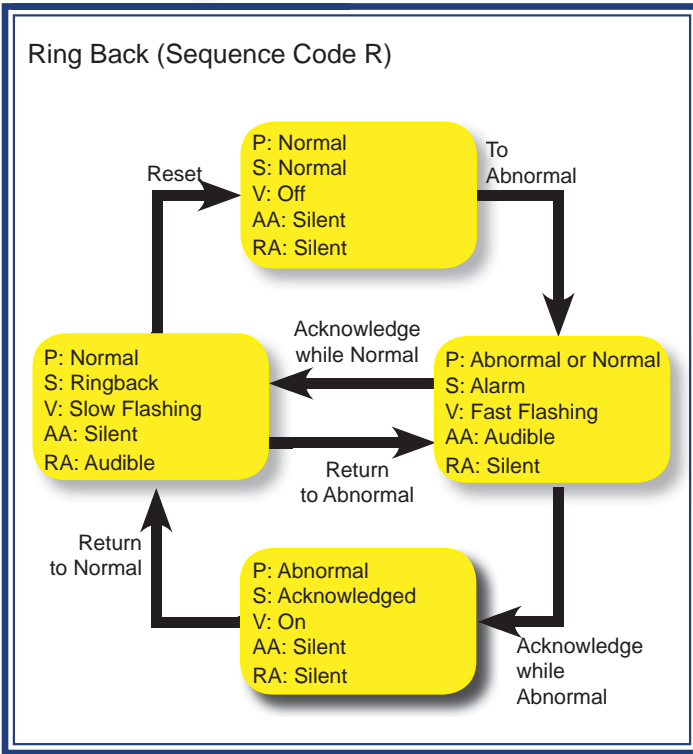

### Legends:

P: Process    S: Sequence    V: Visual    A: Audible    AA: Alarm Audible    RA: Ringback Audible

Visit the bellow links for Manual Reset & Auto Reset demonstrations

<http://www.youtube.com/watch?v=XgYib4a5PoE>  
<http://www.youtube.com/watch?v=j7n6RerSviQ>

## Order Number

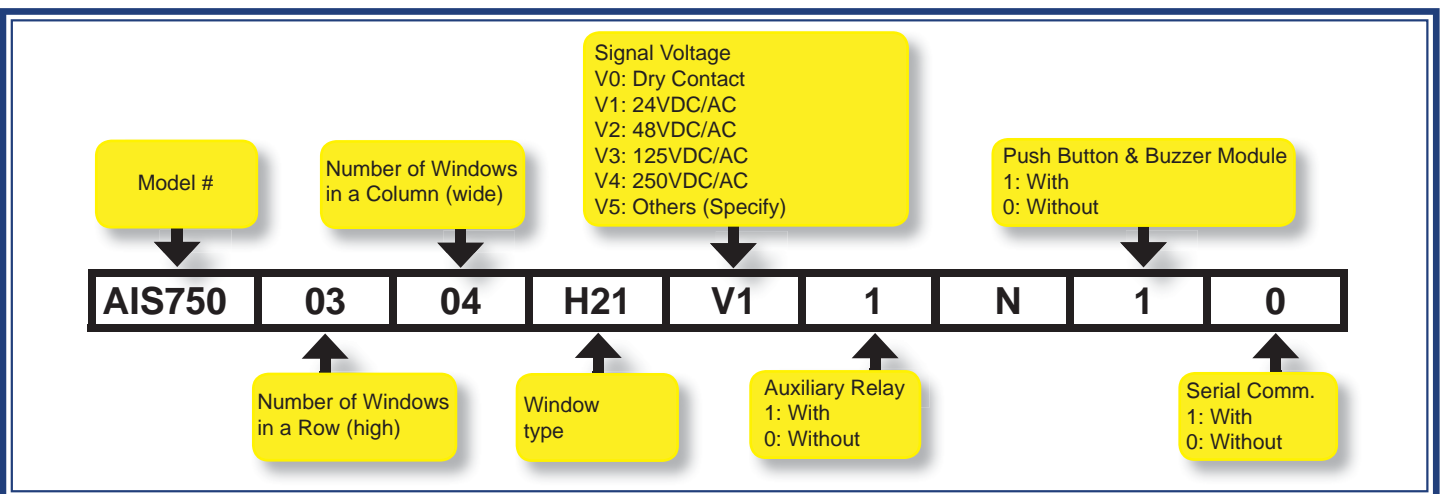

# AIS750 Series Alarm Annunciator

## Optional Features

### Integral Push Button & Buzzer Module (option)

Standard AIS750 Series Annunciator supports four remote Pushbuttons (Acknowledge, Reset, Test, Mute) and two Horns. As an option, an integral "Push Button & Buzzer Module" can be fitted in the bottom right window.



### Auxiliary (Repeat) Relay Module (option)

Each 4 channel Logic Card can be supplied with an optional 4 channel Relay Module (RM) which plugs into Logic Card and provides the user with a dry contact (potential free) contact per alarm channel for use with 3rd party devices. These repeat relays can be configured to operate in accordance with one of the following.

- *Input Follower*: The relay changes state each time there is a change to the associated signal input contact.
- *Output (display) Follower*: The relay changes state on alarm and faithfully follows the display window.

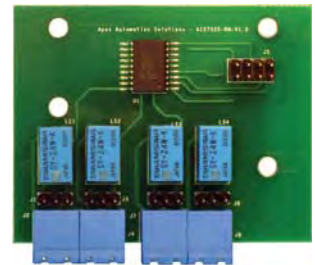

### Serial Communication (option)

For serial communication with other Annunciators or devices or to operate in Modbus mode a Communication Card (Com. Module) plugs into Interface Module to support RS485 and RS232 networks (selectable).

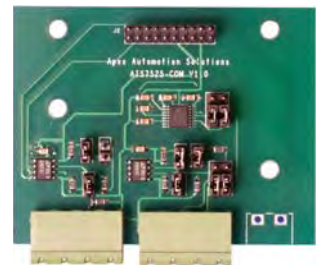

Phone: +1 289 597 APEX(2739)

Fax: +1 289 597 2200

Email: [mail@annunciator.ca](mailto:mail@annunciator.ca)

Web: [www.ANNUNCIATOR.ca](http://www.ANNUNCIATOR.ca)

3-350 John Street, Thornhill, L3T 5W6, Ontario, Canada

Distributed by: